



*AudioAccent™ Assistive Listening System*

*Contains an ALT 1000 Assistive Listening Transmitter  
(with Limiter and Compression)  
and 4 Model MR306 FM Receivers*

---

***Instruction Manual***

*Creating Sound Solutions for Easy Listening™*



WARNING: TO PREVENT FIRE OR ELECTRICAL SHOCK DO NOT EXPOSE THIS PRODUCT'S AC ADAPTER TO RAIN OR MOISTURE

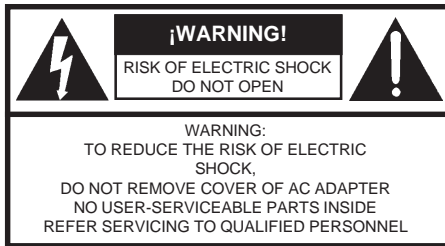

An appliance and cart combination should be moved with care. Quick stops, excessive force and uneven surfaces may cause the appliance and cart combination to overturn.



The lightning flash with arrow head symbol, within an equilateral triangle, is intended to alert the user to the presence of uninsulated "dangerous voltage" within the product's enclosure that may be of sufficient magnitude to constitute a risk of electric shock to persons.



The exclamation point within an equilateral triangle is intended to alert the user to the presence of important operating and maintenance (servicing) instructions in the literature accompanying the appliance.

WARNING: TO REDUCE THE RISK OF FIRE OR ELECTRIC SHOCK, DO NOT EXPOSE THIS PRODUCT'S AC ADAPTER TO RAIN OR MOISTURE. DO NOT OPEN THE CABINET, REFER SERVICING TO QUALIFIED PERSONNEL ONLY.

CAUTION: TO PREVENT ELECTRIC SHOCK, DO NOT USE THE AC ADAPTER WITH AN EXTENSION CORD RECEPTACLE OR OTHER OUTLET UNLESS THE BLADES OF THE AC ADAPTER CAN BE FULLY INSERTED TO PREVENT BLADE EXPOSURE.

ATTENTION: POUR PREVENIR LES CHOCs ELECTRIQUES, NE PAS UTILISER CETTE FICHE POLARISEE AVEC UN PROLONGATEUR, UNE PRISE DE COURANT OU UNE AUTRE SORTIE DE COURANT, SAUF SI LES LAMES PEUVENT ETRE INSEREES A FOND SANS EN LAISSER AUCUNE PARTIE A DECOUVERT.

- 1. Read Instructions**—All the safety and operating instructions should be read before the appliance is operated.
- 2. Retain Instructions**—The safety and operating instructions should be retained for future reference.
- 3. Heed Warnings**—All warnings on the appliance should be adhered to.
- 4. Follow Instructions**—All operating and use instructions should be followed.
- 5. Cleaning**—Unplug this appliance from the wall outlet before cleaning. Do not use liquid cleaners or aerosol cleansers. Use a damp cloth for cleaning.
- 6. Attachments**—Do not use attachments that are not recommended by the manufacturer or they may cause hazards.
- 7. Water and Moisture**—Do not use this product near water—for example, near a bathtub, wash bowl, kitchen sink, laundry tub, in a wet basement, or near a swimming pool—and the like.
- 8. Accessories**—Do not place this product on an unstable cart, stand, tripod, bracket, or table. The product may fall, causing serious injury to a child or adult, and serious damage to the appliance.
- 9. Ventilation**—This product should never be placed near or over a radiator or heat register. This product should not be placed in a built-in installation such as a bookcase or rack unless proper ventilation is provided or the manufacturer's instructions have been adhered to. Any slots or openings in the cabinet are provided for ventilation. To ensure reliable operation of the product and to protect it from overheating, these openings must not be blocked or covered. The openings should never be blocked by placing the product on a bed, sofa, rug, or other similar surface. **KEEP CURTAINS AND OTHER FLAMMABLE MATERIALS OUT OF DIRECT CONTACT WITH THE AC ADAPTER.**
- 10. Power Sources**—This product should be operated only from the type of power source indicated on the marking label of the supplied AC Adapter. If you are not sure of the type of power supplied to your home, consult your appliance dealer or local power company.
- 11. Lightning**—For added protection for this product during a lightning storm, or when it is left unattended and unused for long periods of time, unplug the AC adapter from the wall outlet.

**12. Power Lines**—An outside antenna system should not be located in the vicinity of overhead power lines, other electric light or power circuits, where it can fall into such power lines or circuits. When installing an outside antenna system, extreme care should be taken to keep from touching such power lines or circuits as contact with them may be fatal.

**13. Overloading**—Do not overload wall outlets and extension cords as this can result in a risk of fire or electric shock.

**14. Servicing**—Do not attempt to service this product yourself as opening or removing covers may expose you to dangerous voltage or other hazards. Refer all servicing to qualified service personnel.

**15. Damage Requiring Service**—Unplug this product from the wall outlet and refer servicing to qualified service personnel under the following conditions:

- When the AC adapter cord or plug is damaged.
- If the AC adapter has been exposed to rain or water.
- If the product does not operate normally by following the operating instructions. Adjust only those controls that are covered by the operating instructions. An improper adjustment may result in damage and will often require extensive work by a qualified technician to restore the product to its normal operation.
- If the product has been dropped or the cabinet has been damaged.
- When the product exhibits a distinct change in performance—this indicates a need for service.

**16. Replacement Parts**—When replacement parts are required, be sure the service technician has used replacement parts specified by the manufacturer or have the same characteristics as the original parts. Unauthorized substitutes may result in fire, electric shock or other hazards.

**17. Safety Check**—Upon completion of any service or repairs to this product, ask the service technician to perform safety checks to determine that the product is in proper operating condition.

**18. Outdoor Antenna Grounding**—Before attempting to install this product, be sure the antenna or cable system is grounded so as to provide some protection against voltage surges and built-up static charges.

- Use No.10 AWG (5.3mm<sup>2</sup>) copper, No.8 AWG (8.4mm<sup>2</sup>) aluminum, No.17 AWG (1.0mm<sup>2</sup>) copper-clad steel or bronze wire or larger, as ground wire.
- Secure antenna lead-in and ground wires to house with standoff insulators spaced from 4 feet (1.22m) to 6 feet (1.83m) apart.
- Mount antenna discharge unit as close as possible to where lead-in enters house.
- A driven rod may be used as the grounding electrode where other types of electrode systems do not exist. Refer to the National Electrical Code, ANSI/NFPA 70-1990 for information.
- Use jumper wire not smaller than No.6 AWG 13.3mm<sup>2</sup>) copper or equivalent, when a separate antenna grounding electrode is used.

EXAMPLE OF ANTENNA GROUNDING

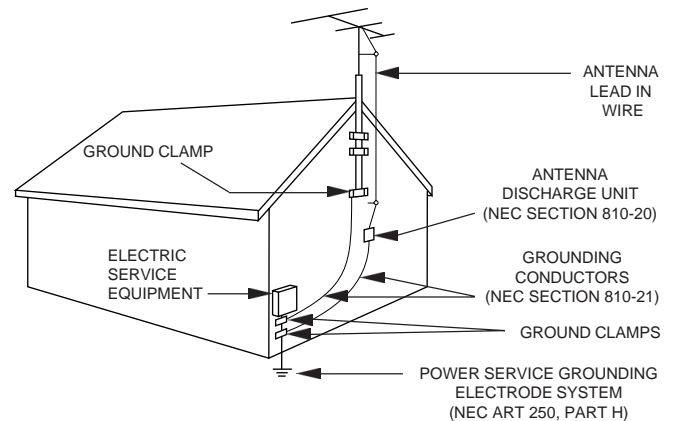

This page left intentionally blank

Thank you for purchasing an AudioAccent™ Assistive Listening System. This product has been designed and manufactured to high quality standards, and will provide reliable operation for many years. Please carefully read the Instruction Manual for proper installation of the transmitter to ensure reliable listening range.

Also included with the system are (3) three AudioAccent™ Assistive Listening System decals. These decals can be posted to inform people that a facility is equipped with the AudioAccent™ Assistive Listening System.

---

<b>Important Safeguards</b>	<b>i</b>
<b>Table of Contents</b>	<b>iii</b>
<b>Specifications / Options and Accessories</b>	<b>iv</b>
<b>Introduction - General Description</b>	<b>1</b>
<b>Front Panel Controls and Indicators</b>	<b>2</b>
<b>Rear Panel Controls and Connections</b>	<b>3</b>
<b>Installation</b>	<b>4</b>
Setup and Operation	<b>4</b>
<b>Operating the MR306 Receiver</b>	<b>6</b>
<b>Service Information / If You Need To Call For Help</b>	<b>8</b>
<b>Warranty</b>	<b>9</b>

## iv Specifications / Options and Accessories

### **SPECIFICATIONS:**

Frequency Coverage:	72.1 to 72.9 MHz, 74.7 MHz, and 75.3 to 75.9 MHz.	Ultimate S/N Ratio (with Drake Model MR306 receiver):	Greater than 60 dB, monaural Greater than 55 dB, stereo
Frequency Selection:	Selectable by front panel ▲/▼ buttons and LCD frequency readout.	Total Harmonic Distortion:	Less than 0.25%, typical.
Frequency Generation:	PLL Synthesis.	Power Requirement:	12 VDC @ 250 mA, regulated by supplied wall AC Adapter.
Frequency Stability:	±10 ppm, 0° to +50° C.	Antenna:	Flexible 7 inch length whip.
Tuning Step Size:	100 kHz.	Size:	19" W x 1.75" H x 6.25" D (with antenna removed).
Modulation:	FM, 200KF8E, multiplex stereo.	Weight:	5 lbs.
FM Deviation:	±75 kHz, maximum.	Agency Approval:	FCC Part 15 Certification. Industry Canada Certification.
Pre-Emphasis:	75 µSec.	Front Panel:	LCD Display of Frequency and Mode, TUNE ▲ / ▼ buttons, Input Level Control with (Over) Modulation Indicators, Monitor output with Monitor Level Control.
RF Field Strength:	80 mV/m @ 3m with supplied flexible antenna ("rubber duck") or optional magnetic mount antenna.	Rear Panel:	Qty (2) XLR connectors (Left and Right Balanced Audio Input) with GROUND LIFT Switch, Qty (2) RCA Phono Connectors (Left and Right Unbalanced Audio Input). Use Left Audio Inputs for Monaural audio input, Limiting/Compression switch, DC Power Input with Power On/Off Switch, and External Antenna connector.
Audio Inputs: Stereo:	2 XLR (left and right audio), 2 RCA Phono (left and right audio). Use Left XLR or Left RCA Phono input.		
Audio Input Level for 75 kHz Peak Deviation- XLR Connectors:	20K Ohm input impedance, balanced. -10 to +10 dBu manual gain adjustment with front panel modulation indicators.		
RCA Phono Connectors:	20K Ohm input impedance, unbalanced. -16 to +4 dBu manual gain adjustment with front panel modulation indicators.		
Frequency Response:	20 Hz to 15 kHz, +1 to -3 dB referenced to a standard 75 µSec pre-emphasis curve.		

### 1) Optional Magnetic-mount Antenna:

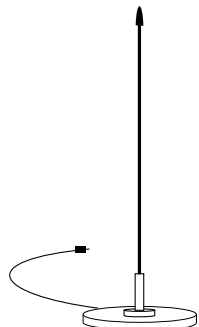

### 2) Additional MR306 Receivers:

#### **MR306 SPECIFICATIONS:**

Frequency Range:	FM 72.0 MHz to 108.1 MHz.
Antenna:	FM Headphone Cord.
10% THD Output Power:	Earphone- 10mW + 10mW, Speaker- 30mW.
Battery:	3 VDC (1.5Vx2) "AAA"/RO3/UM4.
Receiver Accessories:	Stereo Dynamic Headphones (1pair).

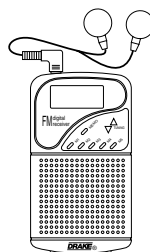

The ALT 1000 is a wideband FM Listening System which operates in the 72 - 76 MHz frequency band. Designed for hearing assistance in places of public access, the ALT 1000 is for those who need help overcoming background noise, reverberation, or distance from the sound source. It is easily integrated with your existing sound system.

The Assistive Listening System has two principal parts: the ALT 1000 Assistive Listening Transmitter, and the MR306 FM Receivers. Audio input to the ALT 1000 is broadcast as an FM signal (72.1 - 72.9 MHz, 74.7 MHz, and 75.3 - 75.9 MHz) to as many MR306 receivers as desired. The receivers pick up the broadcast in an area up to approximately 700,000 square feet (approximate radius of 500 feet).

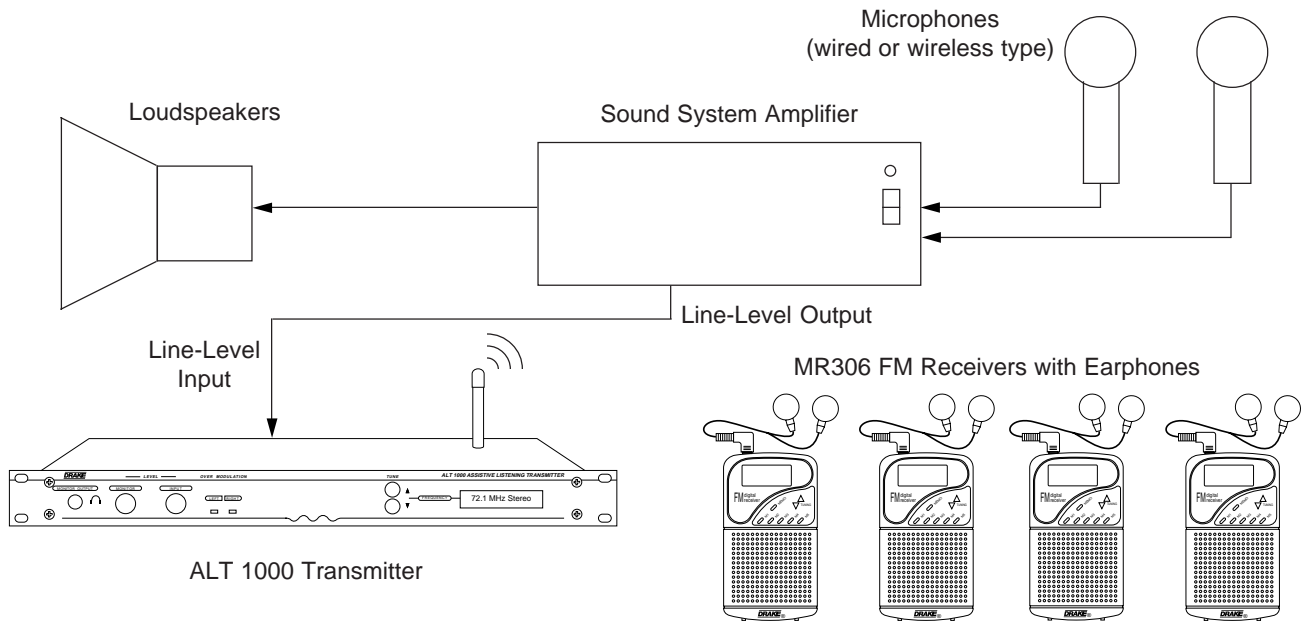

## ARCHITECTURAL AND ENGINEERING SPECIFICATIONS

The transmitter shall operate in the 72 - 76 MHz Auditory Assistance Band as approved by the FCC. Specifically, the transmitter shall operate on the wideband channels spaced at 100 kHz increments on frequencies of 72.1 to 72.9 MHz, 74.7 MHz, and 75.3 to 75.9 MHz. The transmitted field strength shall not exceed 80 millivolts per meter at a 3 meter distance. The operating frequency and mode; Stereo or Mono shall be shown on an LCD display and be programmable by front panel TUNE ▲ / ▼ buttons. The transmitter shall be FCC and Industry Canada approved.

Maximum FM deviation shall not exceed  $\pm 75$  kHz. Frequency stability shall be controlled by a phase-locked loop frequency synthesizer with crystal reference and shall be accurate within  $\pm 0.001\%$  from  $0^\circ$  to  $+50^\circ$  C. The transmitter shall permit fitting of a 7" flexible whip antenna mounted through the top cover of the unit, or permit connection of an optional magnet mount antenna, with coaxial cable, to a rear panel connector. Only the particular antenna type intended for this connection shall be specified.

The transmitter shall have XLR connectors for balanced audio inputs and RCA Phono connectors for unbalanced audio inputs. The transmitter shall provide a GROUND LIFT switch for the XLR inputs. The transmitter shall provide full deviation for monaural input signals to the LEFT AUDIO INPUT connectors when programmed for the MONO mode. The transmitter shall permit switch selection of no limiting, limiting only, or limiting and compression operation from a rear panel switch. There shall be a front panel control to

adjust the audio input level with an LED (OVER) MODULATION indicator.

There shall be a front panel 1/4" stereo monitor jack with volume control.

The transmitter shall be powered by an external AC line to 12 VDC power adapter. The rear panel shall have a power switch and front panel display indication when power is active. The transmitter shall be rack mountable in a standard 1 RU rack package.

The receiver shall be tunable in 100 kHz increments for reception in the 72 - 108.1 MHz Band. Tuning to the required frequency shall be permitted by the ▲ / ▼ TUNING buttons or by user programmable memory recall. The receiver shall have five preset memory channels that are recalled by individual memory channel buttons. The receiver shall be equipped with a LOCK switch to prevent inadvertent setting changes. The receiver shall be set to either STEREO or MONO reception with a switch. The receiver shall have a Volume control. The receiver shall have a 1/8" stereo/mono headphone connector and a switch to select audio output to either the headphone (EAR) connector or to the internal speaker (SPK). The output power shall be 10 mW + 10 mW to the headphone (EAR) connector or 30 mW to the internal speaker. The receiver shall be powered by two "AAA" size, 1.5 V batteries with power controlled by an ON/OFF switch. The headphone wiring shall provide the FM antenna.

The R.L. Drake ALT 1000 Assistive Listening Transmitter with MR306 FM Receiver(s) system is specified.

## 2 Front Panel Controls and Indicators

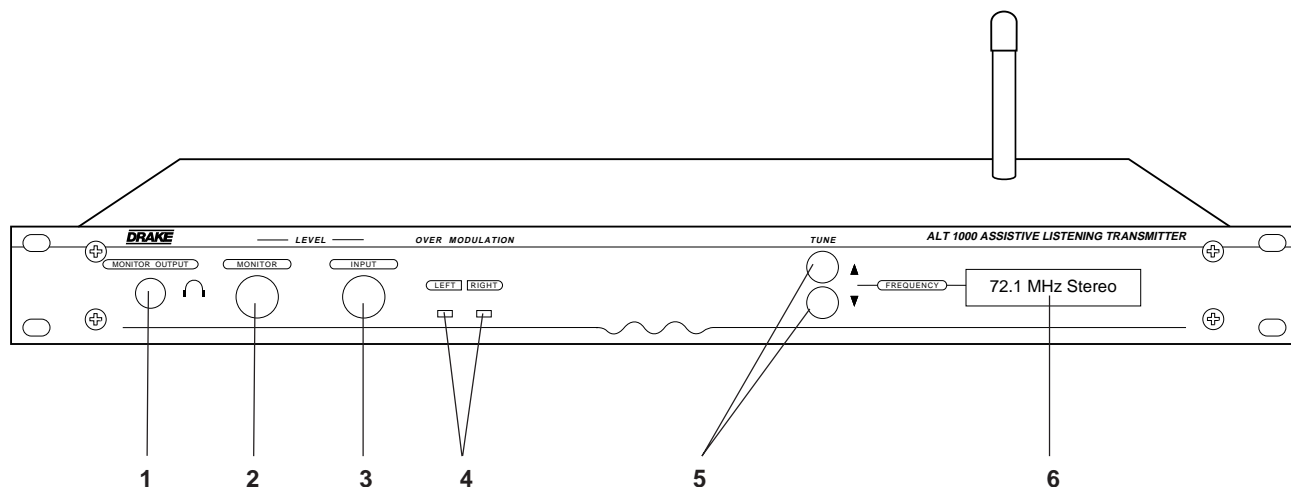

**1. MONITOR OUTPUT** - Connect headphones to listen to the audio that is supplied to the transmitter. The monitored level will vary with the level of the incoming audio, the setting of the INPUT LEVEL control, and the setting of the MONITOR OUTPUT level control.

**2. MONITOR OUTPUT LEVEL Control** - With the INPUT LEVEL control set properly, adjust this control for a comfortable listening level in the connected monitor headphones.

**3. INPUT LEVEL Control** - This control is used to adjust the input sensitivity. For a monaural audio input signal, set this control at or just below the point where the (OVER) MODULATION LED indicators light on audio peaks. For a stereo input signal, set this control at or just below the point where either of the (OVER) MODULATION LED indicators light on audio peaks.

**4. (OVER) MODULATION Indicators** - In this model, these indicators light to aid in the setting of the INPUT LEVEL control for proper modulation. They light to indicate that full modulation is being reached when the rear panel LIMITING/COMPRESSION switch (see rear panel Item 4) is set to "OFF". With the switch set for either the "L" or "C+L" position, these indicators will light on audio signal peaks as the limiter is activated at full modulation. Also see rear panel Item 4 for additional hints for proper setting of the LIMITING/COMPRESSION switch for a given type of audio source. Set the INPUT LEVEL control at or just below the point where the (OVER) MODULATION indicators light on audio peaks.

**5. TUNE ▲ / ▼ Buttons** - Press to set the displayed operating frequency: 72.1 - 72.9 MHz, in 100 kHz increments; 74.7MHz; or 75.3 - 75.9 MHz, in 100 kHz increments. Press and hold both buttons until the displayed 'Mono' or 'Stereo' flashes. Release both buttons and press either ▲ or ▼ to alternately set 'Stereo' or 'Mono' as required. After a short delay, the displayed 'Stereo' or 'Mono' will stop flashing. With a steady 'Stereo' or 'Mono' displayed, the TUNE ▲ / ▼ buttons permit setting the frequency.

**6. FREQUENCY/Mode Display** - Indicates the operating frequency and mode, Mono or Stereo, when the rear panel 'POWER' switch is set to the 'ON' position and the AC Adapter is connected and powered from an AC source.



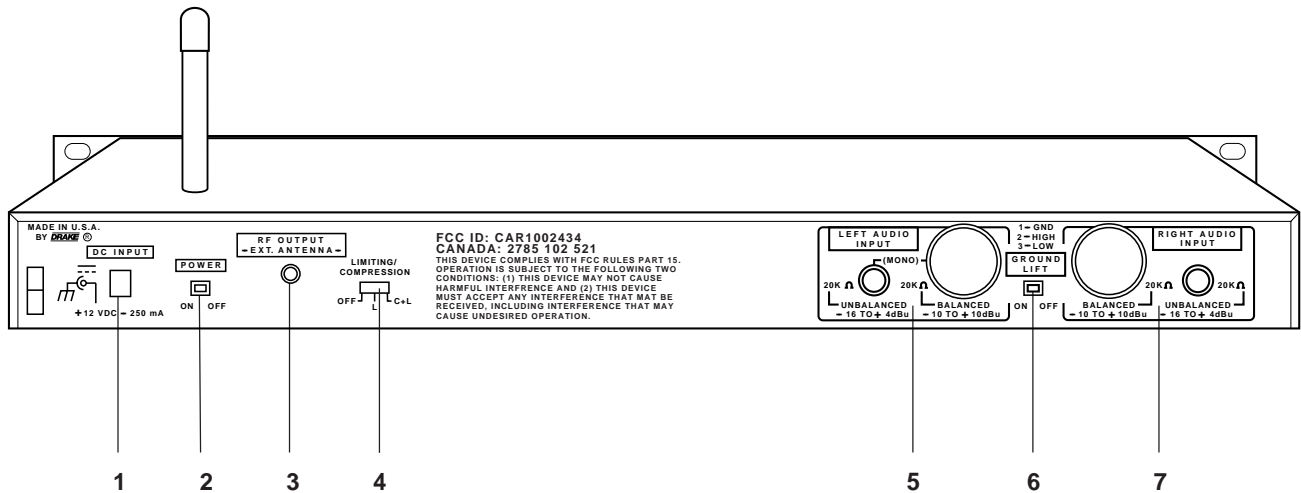

**1. DC INPUT** - Connect the supplied AC Adapter to this connector. Secure AC Adapter DC cable with the adjacent rear panel strain relief.

**2. POWER ON/OFF Switch** - Set this switch to the 'ON' position to operate the ALT 1000.

**3. RF OUTPUT/EXTERNAL ANTENNA** - Connection for the optional magnet mount antenna only. This connector type permits fitting only the R.L. Drake Company supplied magnet mount optional antenna.

**4. LIMITING/COMPRESSION SWITCH** - This switch selects the operation of the limiter. Select the proper, or desired, setting according to the following criteria:

"OFF" - For audio sources with limiting and/or compression already applied. This setting bypasses the limiting circuitry of the ALT 1000. With the audio source connected, adjust the INPUT LEVEL control to a setting at or just below the point where the (OVER) MODULATION indicators light on audio peaks.

"L" - For most types of audio sources and listening environments. This setting provides automatic limiting on audio peaks to prevent loud bursts and to avoid over modulation conditions which can cause distorted audio at the receiver. With the audio source connected, (for example, the output of a public address amplifier with a person speaking at a normal level into the microphone), adjust the INPUT LEVEL control to a setting at the point where the (OVER) MODULATION indicators light on audio peaks.

"C+L" - For audio sources that contain relatively low audio levels combined with relatively high audio levels as might be encountered when the audio output from a public address amplifier contains audio from multiple microphones with different persons speaking. This setting provides automatic increasing of the low level audio passages combined with limiting on voice peaks. This type of audio processing can sometimes aid intelligibility for a person receiving the signal while located in a relatively noisy audio environment. With the audio source connected, and the weaker audio levels active, adjust the INPUT LEVEL control to a setting at or just below the point where the (OVER) MODULATION indicators light on audio peaks.

**5. LEFT AUDIO INPUT** - Connect monaural audio input signals to the appropriate unbalanced or balanced LEFT AUDIO INPUT connector. For monaural input, program the ALT 1000 to display 'MONO'. See Item 5; 'TUNE ▲ / ▼ Buttons' in the 'Front Panel Controls and Indicators' section of this manual. For stereo input, connect an unbalanced line level left channel stereo audio signal to the phono connector or connect a balanced line level left channel stereo audio signal to the 3-pin female XLR connector. The unbalanced phono style input and the XLR balanced input on a given input (Left or Right) are each always active, so audio will be fed from whichever input is being used. **Do not attempt to connect signals to both the unbalanced and balanced connectors on a given input (Left or Right).** All inputs can be considered high impedance ( $\geq 20K$  Ohm). The shield connection at pin 1 of the XLR connector can be conveniently connected to ground (GROUND LIFT = 'OFF') or lifted from ground (GROUND LIFT = 'ON') to eliminate hum or noise as required. For stereo input, program the ALT 1000 to display 'STEREO'. See 'Front Panel Controls and Indicators: See Item 5; 'TUNE ▲ / ▼ Buttons' in the 'Front Panel Controls and Indicators' section of this manual.

**6. GROUND LIFT Switch** - Set to the 'OFF' position to connect pin 1 of both LEFT and RIGHT XLR connectors to ground. Set to the 'ON' position to disconnect both XLR connectors from ground.

**7. RIGHT AUDIO INPUT** - For stereo input, connect an unbalanced line level right channel stereo audio signal to the phono connector or connect a balanced line level right channel stereo audio signal to the 3-pin female XLR connector. Never connect signals to both the unbalanced and balanced connectors on a given input (Left or Right). The shield connection at pin 1 of the XLR connector can be conveniently connected to ground (GROUND LIFT = 'OFF') or lifted from ground (GROUND LIFT = 'ON') to eliminate hum or noise as required. For stereo input, program the ALT 1000 to display 'STEREO'. See Item 5; 'TUNE ▲ / ▼ Buttons' in the 'Front Panel Controls and Indicators' section of this manual. Connect a monaural audio signal to the appropriate LEFT AUDIO INPUT connector. See Item 5: 'LEFT AUDIO INPUT', on this page.

# 4 Installation

## SETUP and OPERATION

### Locating the ALT 1000

Prior to connection and adjustments, decide on a location for the ALT 1000 that will provide a reliable signal to the receivers throughout the intended listening area. Generally, for the best transmitted signal coverage, locate the ALT 1000 in an area that is free of metal obstructions and closest to the intended listening area. If the supplied "rubber duck" antenna is to be used, do not locate the ALT 1000 in a metal cabinet.

### 1. Install the antenna

The "rubber duck" antenna fits into the hole on top of the transmitter and threads onto a mounting stud inside. Guide the antenna onto the stud and turn it clockwise to tighten. Do not use excessive force to tighten the antenna; it only needs to be finger-tight.

Tighten

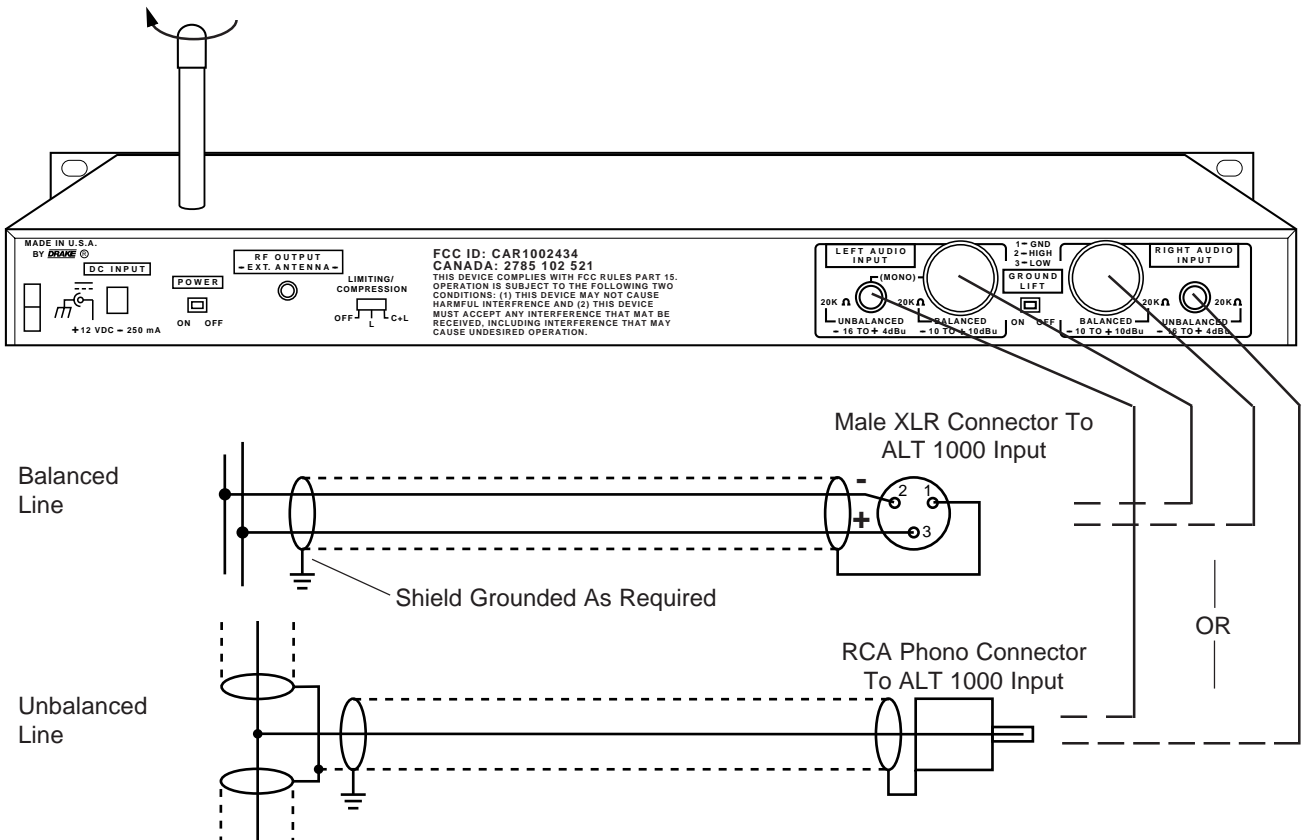

If the optional magnetic-mount antenna is more appropriate, contact your dealer or the R.L. Drake Company. The magnetic-mount antenna installation and placement is detailed on page 5 of this manual.

### 2. Make audio connections

The ALT 1000 will accept line level audio inputs. The best sources for a signal from a sound system are as follows:

1. TAPE OUT or LINE OUT
2. BOOSTER or BRIDGING
3. Speaker Terminal

Use XLR connectors to connect balanced audio signals to the ALT 1000 AUDIO INPUTS. Use RCA phono connectors to connect unbalanced audio signals to the ALT 1000 AUDIO INPUTS. The following diagrams illustrate balanced and unbalanced audio wiring details:

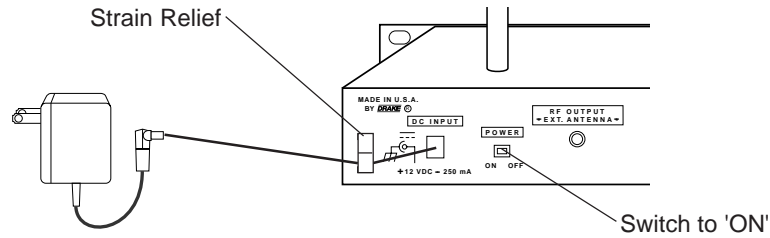

### 3. Connect the Transmitter to Power

Plug the DC power cord of the supplied AC Adapter into the DC INPUT connector on the rear panel of the ALT 1000 unit. Secure the DC power cord with the adjacently located strain relief. Plug the AC Adapter into a nominal 120 VAC, 60 Hz wall outlet. Set the rear panel POWER switch to the 'ON' position. The front panel display should now indicate the operating frequency and mode.

If a monaural audio source is being supplied to the ALT 1000, set the displayed mode to 'MONO'. Set for 'STEREO' with stereo audio source material. To set the mode, press and hold both TUNE ▲ / ▼ buttons until the mode 'MONO' or 'STEREO' flashes. Press either TUNE ▲ / ▼ button to set the required mode.

### 4. Set the Operating Frequency and Mode

Determine a frequency in the range of 72.1 - 72.9 MHz, 74.7 MHz, or 75.3 - 75.9 MHz that is not active in your area. Use one of the supplied MR306 receivers to monitor the intended frequency. Press the front panel ▲ / ▼ button(s) of the ALT 1000 to set the operating frequency. A receiver set to the same operating frequency should become quiet.

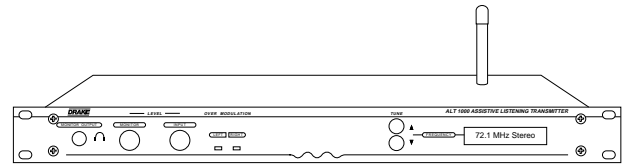

### 5. Set the INPUT and MONITOR Level Controls

With the audio source active, and the desired type of limiting set, adjust the INPUT LEVEL control clockwise until the (OVER) MODULATION LED indicators just begin to light on audio signal peaks. Refer to the "Rear Panel Controls and Connections" (Item 4) and the "Front Panel Controls and Indicators" (Items 3,4) sections of this manual for details. To monitor the audio source material, plug a set of headphones into the MONITOR OUTPUT jack. Adjust the MONITOR Level control for a comfortable listening level.

### Locating the Optional Magnetic-Mount Antenna

The optional magnetic-mount antenna is intended for use with rack-mounted transmitters or in installation areas where a remote antenna is needed for maximum operating distance. For maximum signal strength, it is best to locate the antenna somewhere within the listening area. Generally, the higher the antenna can be mounted above the listening area, the better.

Per FCC rules, only antennas supplied by the R.L. Drake Company may be used with this transmitter.

### Installing the Remote Antenna

1. Remove the "rubber duck" antenna from the ALT 1000 by turning it counterclockwise and guiding it through the top cover.
2. Attach the optional antenna to the rear panel 'RF OUTPUT - EXT ANTENNA' connector. CAUTION: This connector is a left-hand thread type. The mating connector on the coaxial cable feed for the antenna tightens in a COUNTERclockwise direction.

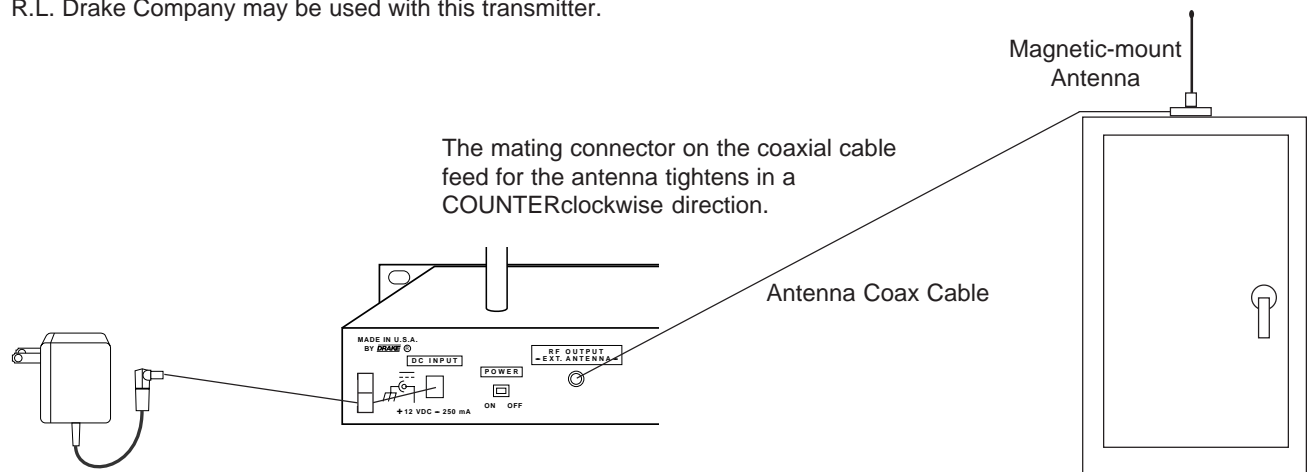

## 6 Operating the MR306 Receiver

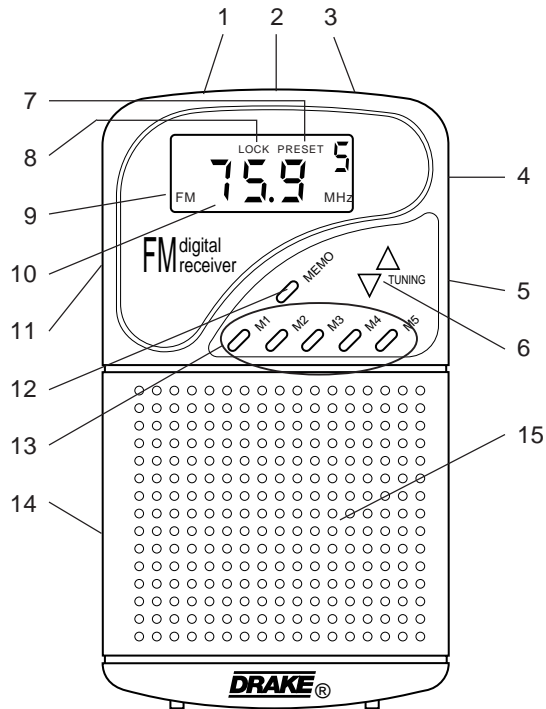

1. Phone Jack
2. Power ON/OFF Switch
3. Volume Control
4. FM MONO Stereo Switch
5. Key LOCK Switch
6. TUNING Buttons
7. Memory Indicator
8. Key Lock Indicator
9. FM Stereo Indicator
10. LCD Display
11. Ear/Speaker Selector Switch
12. Memory Button (MEMO)
13. Station Preset Buttons
14. Battery Compartment
15. Speaker

### POWER SUPPLY

Slide open the battery compartment cover (14) on the back of the unit and insert two "AAA" (RO3/UM4) dry cells. Make sure the "+" and "-" markings on the batteries match the markings inside the compartment.

- Do not mix old and new batteries.
- Do not mix alkaline, standard (carbon-zinc) or rechargeable (nickel-cadmium) batteries.
- If the LCD display is flashing or shuts off during operation, the batteries should be replaced.

### OPERATION

The intended use of this receiver is for assistive listening. For that type of system, earphones are generally used so that any background noise is eliminated. It is also important to note that the wires of a connected earphone also work as an antenna with this receiver, thereby providing more reliable signal reception.

1. Set the EAR/SPK switch (11) to the "EAR" position. Use the "SPK" position for general radio listening, as desired. As previously explained, the wires of a connected earphone provide better reception regardless of the EAR/SPK switch setting.

2. Connect the Earphones to the Phone Jack (1).

3. Set the ON/OFF switch (2) to the "ON" position.

4. Press the TUNING ▲ or ▼ button (6) to tune to the desired frequency. When either button is pressed for more than one (1) second, the receiver will scan for the next available frequency. The scan mode will stop automatically when a signal is found. The automatic scan will continue to scan a band even after the search reaches the minimum or maximum frequency of that band. Once the search reaches maximum frequency, the receiver will return to minimum frequency and continue the search.

- Press the TUNING button (6) again to select the desired frequency.

5. Adjust the volume control (3) to the desired level.

6. Set the FM "MONO/Stereo" switch (4) to the desired choice.

## PRESET TUNING

Once the desired frequencies are stored in the preset buttons (13), they can easily be recalled.

To store a station into memory, use the following sequence:

1. Tune to a desired frequency.
2. Press the "MEMO" (12) button and a blinking Memory indicator (7) will appear on the LCD display (10).
3. While the memory indicator is blinking, press one of the five preset buttons (13) to store the frequency. The memory indicator light will turn off 15 seconds later, if no other preset buttons are pressed.

## MEMORY RECALL

Recall a stored frequency by simply pressing the appropriate preset button (M1-M5).

## MEMORY BACKUP OF STORED FREQUENCIES

When the batteries are low, the LCD display will flash or turn off. If this occurs, switch the "ON/OFF" switch to the "OFF" position. Then install new batteries. The new batteries must be installed within one minute of the time that the old batteries are removed in order to save the frequencies stored into memory.

## SUGGESTIONS FOR RECEIVER MANAGEMENT

Different types of facilities will use varied approaches for receiver management and earphone sanitation. The following includes some options that customers have used successfully:

1. Regular users purchase their own receiver and maintain the batteries and earphone.
2. Some facilities label each receiver and earphone with the name of the person to which the receiver/earphone is assigned and used.
3. Ushers issue receivers to those people who request them. Earphones are sanitized after each use. Foam ear cushions can be replaced or washed with a mild detergent, rinsed thoroughly, and air-dried. Certain models of earphones can be sanitized with an alcohol pad.
4. The receivers can be stored in a multiple storage case with a credit card or driver's license left as collateral for the receiver.
5. Regular users purchase their own earphone or headphone and bring them to use with receivers at the facility.

## Examples for wearing the MR306 receiver:

*Placed in a pocket:*

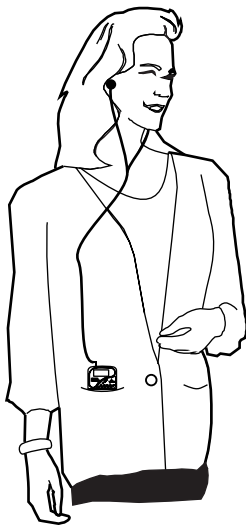

*To assemble belt clip to receiver:*  
1. Apply double-stick tape (A) to plastic belt clip (B).

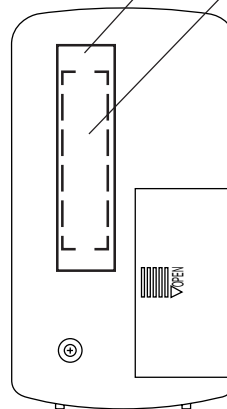

2. Stick clip in desired location on the back of the receiver, without covering the battery cover.

*Clipped onto a belt:*



### **SERVICE INFORMATION**

You may contact R.L. DRAKE Service Department for additional information or assistance by calling (937) 746-6990, Monday through Friday, 8:00 A.M. - 5:00 P.M. EST, except on holidays.

You may also contact the R.L. DRAKE Service Department by E-mail at the following address: [service@rldrake.com](mailto:service@rldrake.com)  
or by Telefax:  
+1 (937) 743-4576.

Should you want to return your unit for service, package the receiver carefully using the original carton or other suitable container.

Write your return address clearly on the shipping carton and on an enclosed cover letter describing the service required, symptoms or problems. Also include your daytime telephone number and a copy of your proof of purchase.

The unit will be serviced under the terms of the R.L. DRAKE COMPANY Limited Warranty and returned to you.

---

### **IF YOU NEED TO CALL FOR HELP**

Call our Customer Service/Technical Support line at (937) 746-6990 between 8:00 a.m. and 5:00 p.m. EST, weekdays. Please have the unit's serial number available. We will also need to know the specifics of any other equipment connected to the unit.

When calling, please have the unit up and running, near the phone if possible. Our technician(s) will likely ask certain questions to aid in diagnosis of the problem. Also, have a voltmeter handy, if possible.

R.L. DRAKE also provides technical assistance by e-mail: [service@rldrake.com](mailto:service@rldrake.com)  
or by Telefax: +1 (937) 743-4576.

Many of the products that are sent to us for repair are in perfect working order when we receive them. For these units, there is a standard checkout fee that you will be charged. Please perform whatever steps are applicable from the installation sections of the Owner's Manual before calling or writing—this could save unnecessary phone charges. Please do not return the unit without contacting R.L. DRAKE first: it is preferred to help troubleshoot the problem over the phone (or by mail) first, saving you both time and money.

Inside the carton, enclose a note with your name, address, daytime phone number, and a description of the unit's problem.

The unit must be sent to the following address:

Service Department  
R.L. DRAKE Company  
230 Industrial Drive  
Franklin, Ohio 45005 U.S.A.

Be sure to include your street address which will be needed for UPS return. UPS Surface (Brown Label) takes 7-10 days to reach us depending on your location, Blue takes 2-3 days. Red is an overnight service and is expensive. Send the unit in a way that it can be traced if we can't verify receipt of shipment. We suggest UPS or insured postal shipment.

If the unit is still under the original owner's warranty, R.L. DRAKE will pay the cost of the return shipment to you. Our return shipping policy is that we will return it UPS Brown if received Brown or by US Mail, it will be returned Blue if received Blue or Red—or it will be returned however you prefer if you furnish the return cost for the method you select.

If the unit is out of warranty, it will be returned by UPS Brown label COD (UPS does not accept cash/currency) unless:

- 1) It was received UPS Blue/Red, in which case it will be returned UPS Blue/Red COD;
- 2) You designate billing to American Express, VISA, MasterCard or Discover card;
- 3) You prepay the service charges with a personal check, or
- 4) You specify some other method of return.

When calling, the technician can estimate the repair charges for you over the phone. This is another good reason to call before sending a unit in for repair.

Typically, equipment is repaired in five to ten working days after it arrives at R.L. DRAKE if we have all the facts. If we must call you, it may take longer.

R.L. DRAKE is not responsible for damage caused by lightning, nonprofessional alterations, "acts of God", shipping damage, poor storage/handling, etc.

R.L. DRAKE will make note of any shipping damage upon receipt.

Should your warranty card not be on file at R.L. DRAKE, you will need to send proof of purchase to receive warranty service. Typically, a copy of the invoice from an R.L. DRAKE dealer will suffice. The warranty is for the original owner only and is not transferable.

## Three Year Limited Warranty

R.L. DRAKE COMPANY warrants to the original purchaser this product shall be free from defects in material or workmanship for three (3) years from the date of original purchase.

During the warranty period the R.L. DRAKE COMPANY or an authorized Drake service facility will provide, free of charge, both parts and labor necessary to correct defects in material and workmanship. At its option, R. L. DRAKE COMPANY may replace a defective unit.

To obtain such warranty service, the original purchaser must:

- (1)** Retain invoice or original proof of purchase to establish the start of the warranty period.
- (2)** Notify the R.L. DRAKE COMPANY or the nearest authorized service facility, as soon as possible after discovery of a possible defect, of:
  - (a) the model and serial number,
  - (b) the identity of the seller and the approximate date of purchase; and
  - (c) A detailed description of the problem, including details on the electrical connection to associated equipment and the list of such equipment.
- (3)** Deliver the product to the R.L. DRAKE COMPANY or the nearest authorized service facility, or ship the same in its original container or equivalent, fully insured and shipping charges prepaid.

Correct maintenance, repair, and use are important to obtain proper performance from this product. Therefore carefully read the Instruction Manual. This warranty does not apply to any defect that R.L. DRAKE COMPANY determines is due to:

- (1)** Improper maintenance or repair, including the installation of parts or accessories that do not conform to the quality and specifications of the original parts.
- (2)** Misuse, abuse, neglect or improper installation.
- (3)** Accidental or intentional damage.

All implied warranties, if any, including warranties of merchantability and fitness for a particular purpose, terminate three (3) years from the date of the original purchase.

The foregoing constitutes R.L. DRAKE COMPANY'S entire obligation with respect to this product, and the original purchaser shall have no other remedy and no claim for incidental or consequential damages, losses or expenses. Some states do not allow limitations on how long an implied warranty lasts or do not allow the exclusions or limitation of incidental or consequential damages, so the above limitation and exclusion may not apply to you.

This warranty gives you specific legal rights and you may also have other rights which vary from state to state. This warranty shall be construed under the laws of Ohio.

### For service information contact:

**Service Department  
R.L. DRAKE COMPANY  
230 Industrial Drive  
Franklin, Ohio 45005 U.S.A.**

**Customer Service Center Phone: +1 (937) 746-6990 TELEFAX: +1 (937) 743-4576**



**R.L. DRAKE COMPANY**  
230 INDUSTRIAL DRIVE  
FRANKLIN, OHIO 45005 U.S.A.  
**CUSTOMER SERVICE AND PARTS TELEPHONE:**  
+1 (937) 746-6990  
**TELEFAX:**  
+1 (937) 743-4576  
**WORLD WIDE WEB SITE: <http://www.rldrake.com>**